

Bending Center



Full Servo-
Electric System

Full
Automatic

Stabil
Process

Clever
Consumption

Rapid
Setup



As a total supplier for sheet metal manufacturing with almost 70 years of experience, Durma understands and recognizes the challenges, requirements and expectations of the industry. We strive to satisfy the ever higher demands of our customers by continuously improving our products and processes while researching and implementing the latest technologies

In our three production plants with a total of 150.000 m², we dedicate 1,000 employees to delivering high quality manufacturing solutions at the best performance-to-price ratio in the market.



**PRODUCTION IS
MORE EFFECTIVE NOW**

From the innovations developed at our Research & Development Center to the technical support given by our worldwide distributors, we all have one common mission: to be your preferred partner.

Durmazlar offers it's machines to the world markets under the Durma brand.



1

High technology,
modern production
lines



2

Top quality
components



3

High quality
machines designed
in R&D Centre

Bending Center

General Specifications

- Full Servo-Electric System
- Full Automatic
- Stabil Process (High Quality)
- Clever Consumption System
- Compact Solution
- Ergonomic and Safe Working Area
- Energy Safety With Clever Consumption System
- Regular Production Independent From the Operator
- Stabil Process (No Influence) From The Machine Thermal Condit

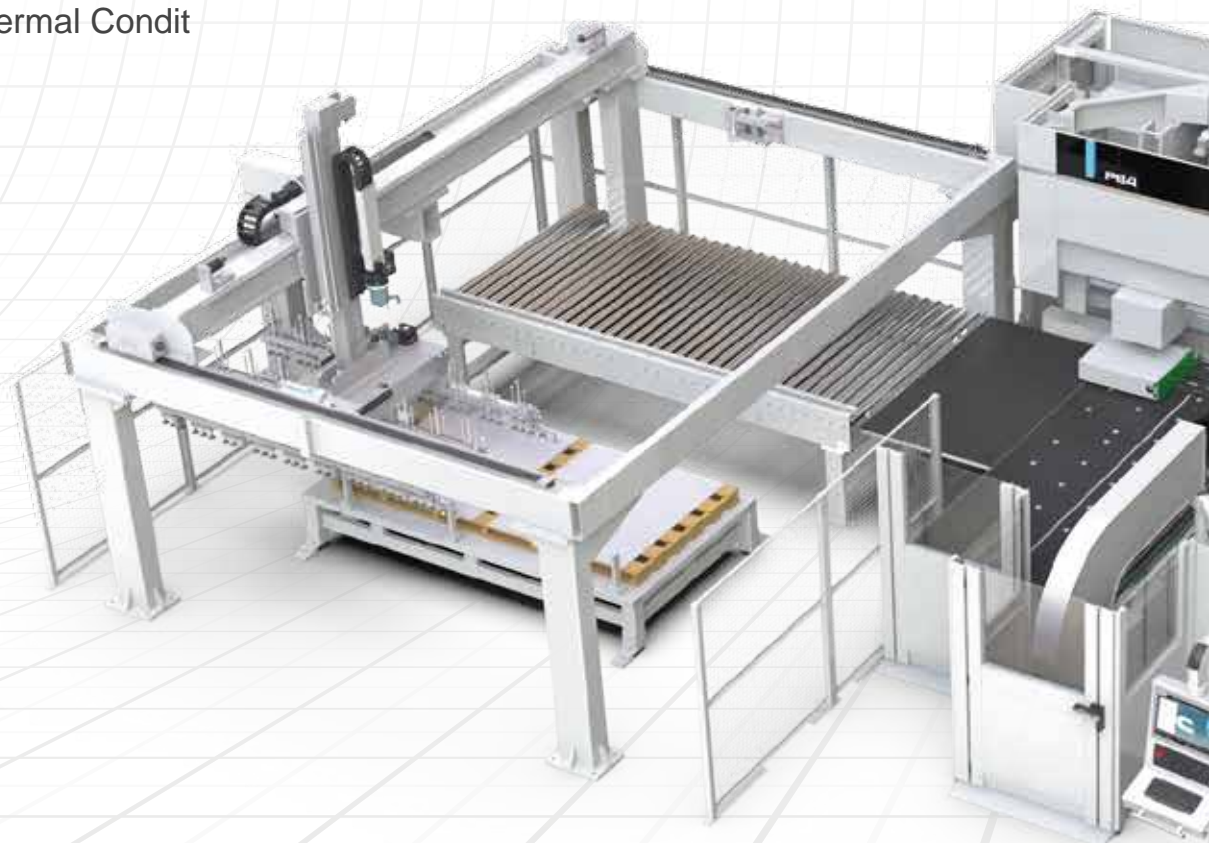
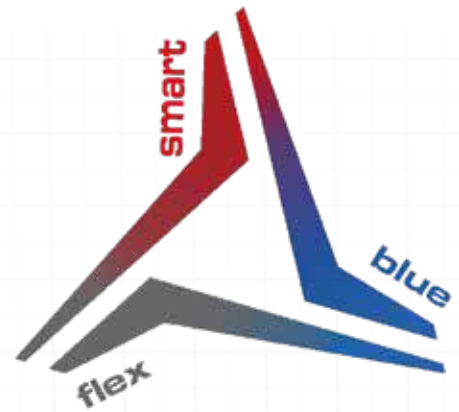

Production is *More Effective Now.*

ENERGY Perfectly Equipped for Bending

EFFICIENT SOLUTIONS

Precise bend with, maximum speed, safety full automatic tool changing and minimum set-up time. With its easy to use control units, rigid body frame, perfect design, high efficiency, multiple tool usage solutions.

Easy to Use

Ergonomic

Efficient

Fast

Reliable Brand

blue bend

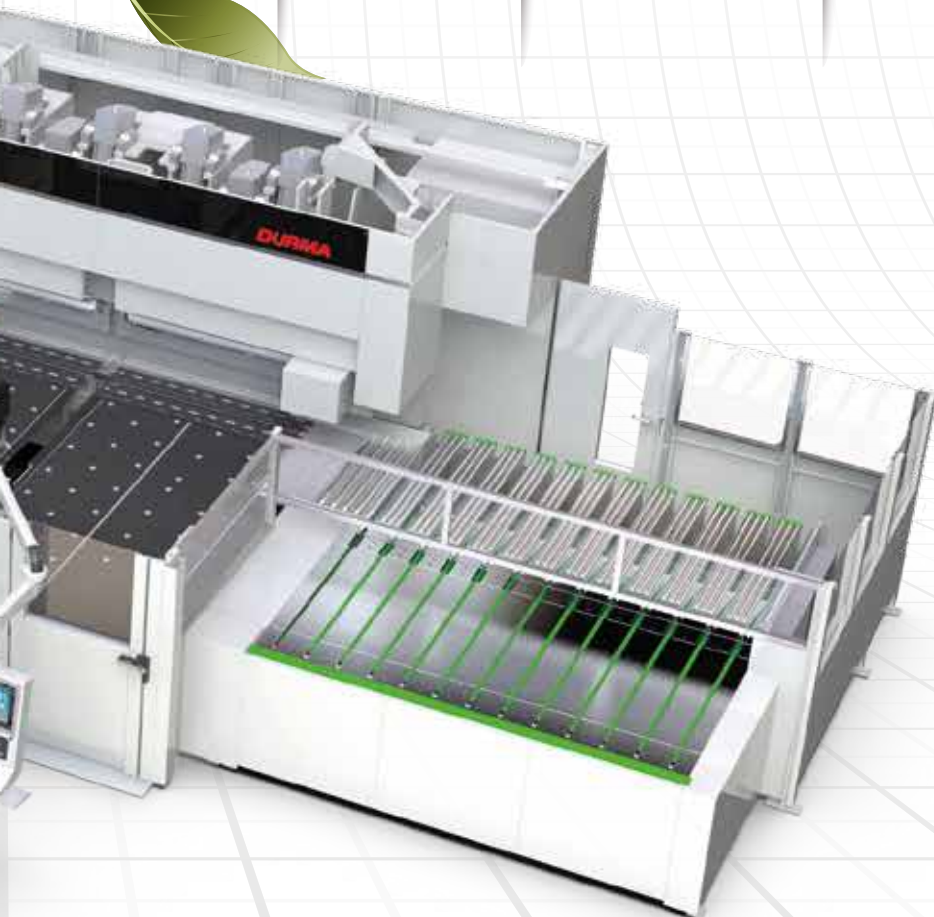

Bending Center

SMART, BLUE,

FLEX

DURMA CNC Bending Center, designed with high technology to increase efficiency on precise part bending.
Quality approved components used.
Stress relieved made on bodies for long life and precise bending.

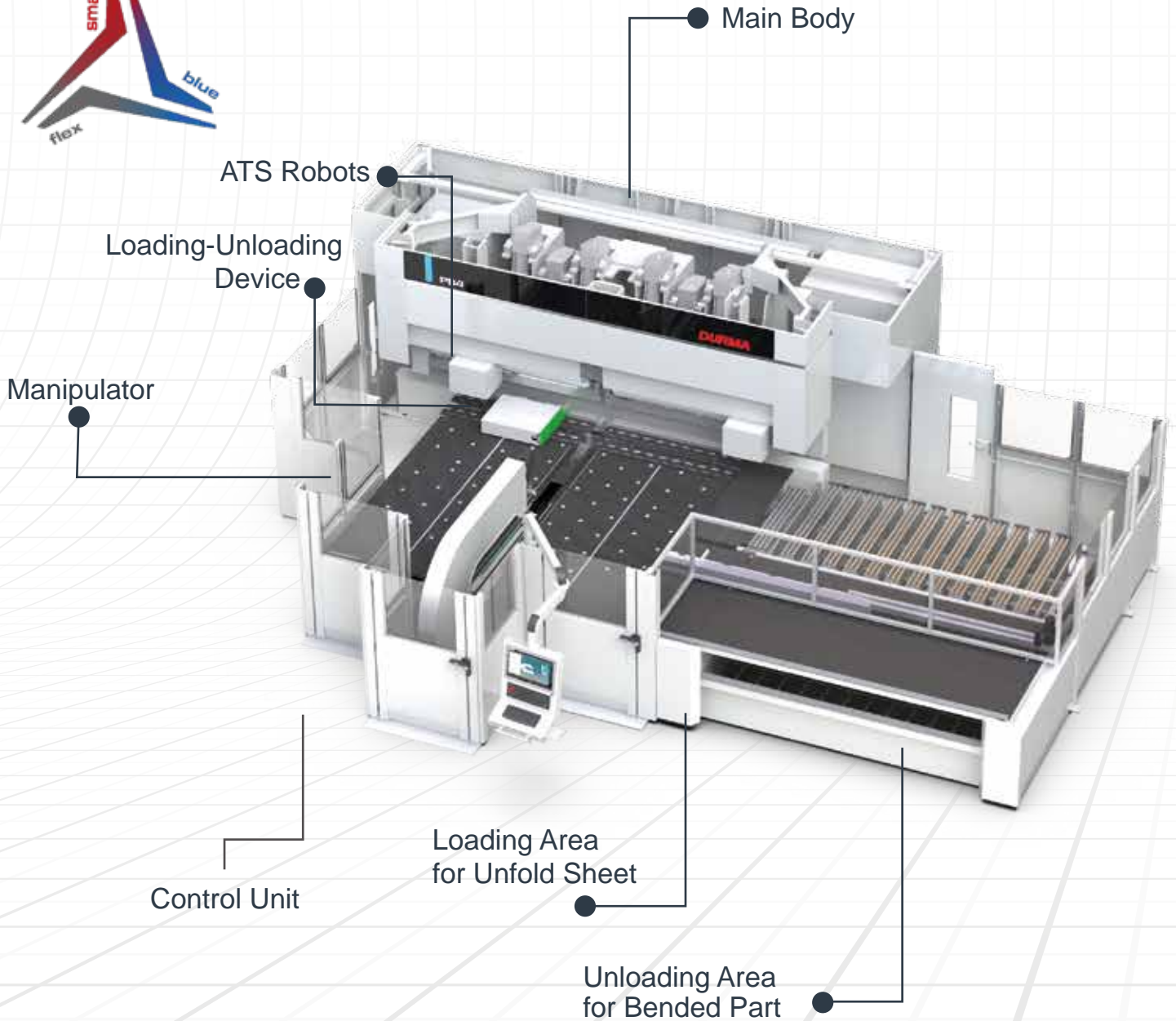
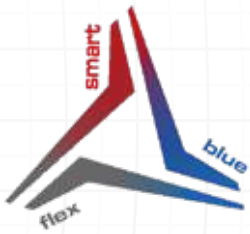

Standart Equipments

Main Frame

Consists of 5 independent sub-body groups. The advantage is to create an independent structure that is unaffected by holding and bending operations. When the holder device is in the hold state, the body stretches backwards in the negative bend state. Advantage, both groups are not affected by each other's stretching during their work.

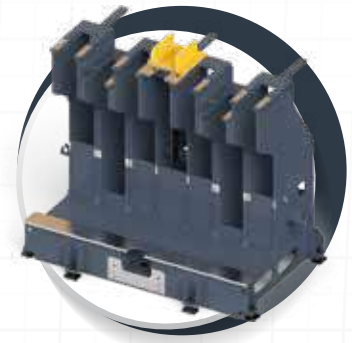

Holder Device

The mechanism that prevents the sheet from slipping, which provides balance against the force applied by the bending device during the bending of the sheet brought to the bending position in the bending area.



Holder Device Crowning

The machine provides the same bend quality for material changes such as Inox, aluminum, DC01 and thickness changes. The same results could be obtained with repeatability and linearity from each bend.

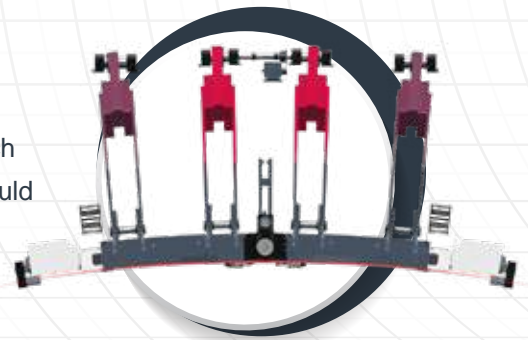

Bending Device

The mechanism that bends the material by bringing the bending device body to the appropriate bending position by the movements of the actuators.



Bending Device Crowning

The machine provides the same bend quality for material changes such as Inox, aluminum, DC01 and thickness changes. The same results could be obtained with repeatability and linearity from each bend.

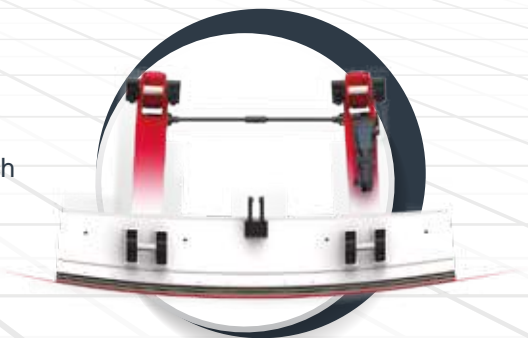

Bending Center

Standart Bending Tools

Bending performance increased using with high quality holding and bending tools **DURMA** is your solution partner with various tool options.

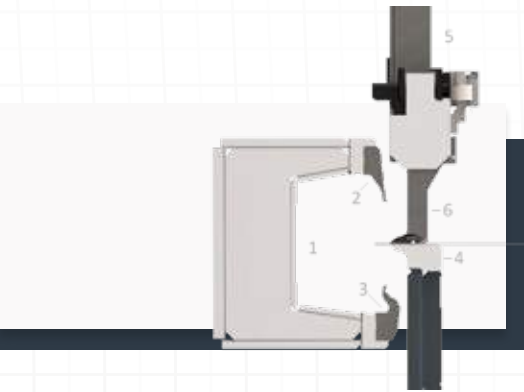

- Bending Device⁽¹⁾
- Upper Blade⁽²⁾
- Lower Blade⁽³⁾
- Bottom Tool⁽⁴⁾
- Holder Device⁽⁵⁾
- Holding Tools⁽⁶⁾

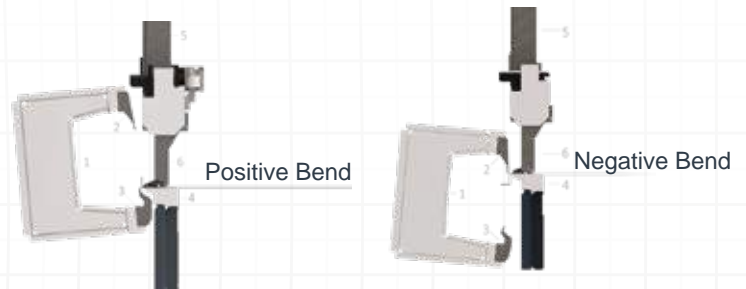

ATS

(Automatic Tool Setup)

Mentioned tools in this section are holder device tools. It is used to adjust the tool lengths for the short and long edge according to the bending shape of the sheet and to adjust the tool length between short to long, long to short operation.

For lateral tools, the robots are positioned symmetrically on the linear slides, left and right, and tool change is performed. Servo motor driven. For thin tools, the required tools are attached or removed by the clamp system located on the right and left sides of the central tool holder. Pneumatic cylinder driven. Tool changing operation with ATS is performed automatically by calculating the required tool configuration according to the bending length on the program

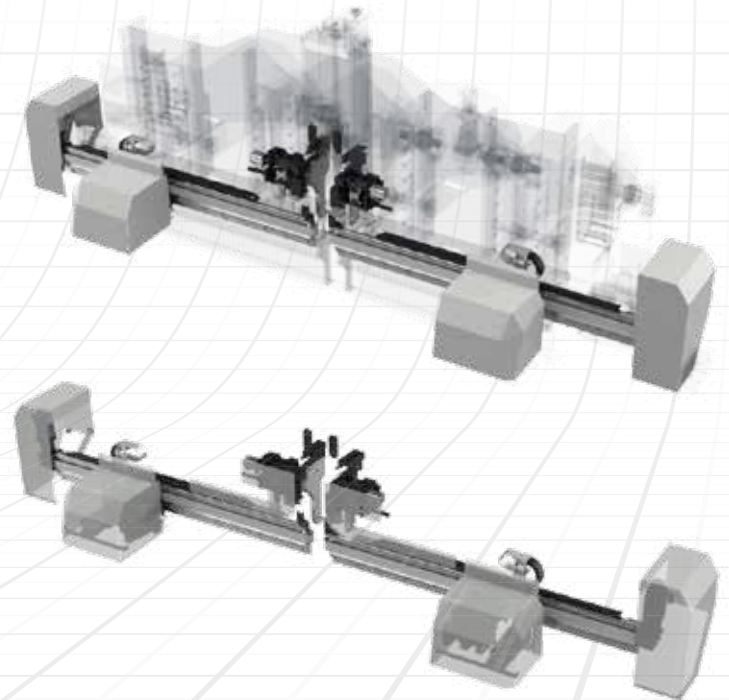

Step for length variation is 6 mm.

LUD

(Loading / Unloading Device)

Servo driven. It moves along the path formed parallel to the bending axis. It consists the pusher group and clamp group. Clamp assembly is used for loading the expansion sheet, and pusher assembly is used for evacuating the bent sheet.

It is the group that enables the sheet metal to be bent to be load to the bending area (below the manipulator clamp) and to evacuate the finished part from the bending area. It is the system that provides the flow between the loading and unloading area of the part to be bent.

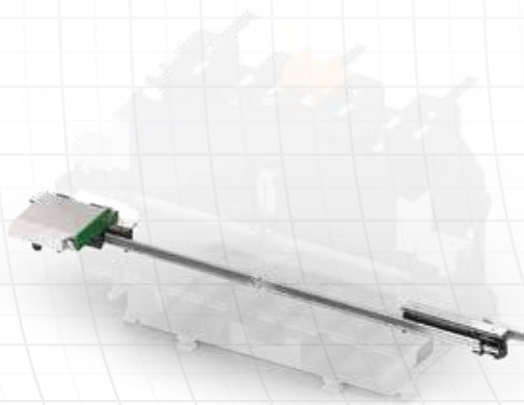
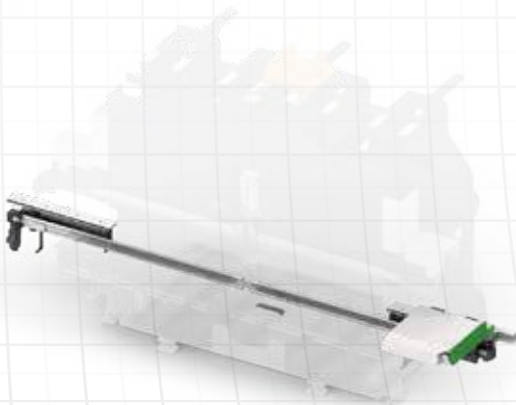
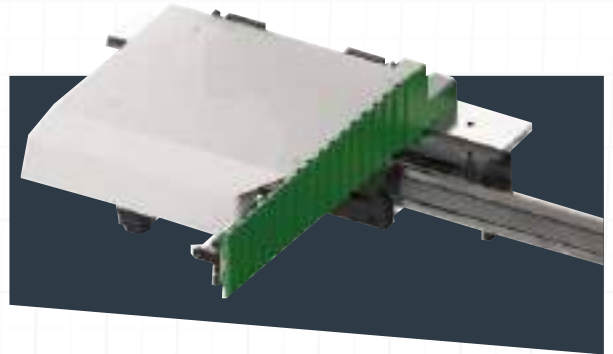

Centering Device

Centering is the process of aligning the bending line of the part to be bent to the machine bending axis. The Centering Device is the group that enables the positioning pins on the part to be referenced to the reference points on the part for the referencing process. The reference pins move symmetrically or asymmetrically to the minimum and maximum points using the ball screw. The reference pins consist of 4 pin reference mechanisms which are positioned opposite each other and 90 ° on the right and left tables of the reference group. The reference pins can be used independently of each other according to the reference suitability of the part. The positioning of the reference pins is set by the operator during programming.

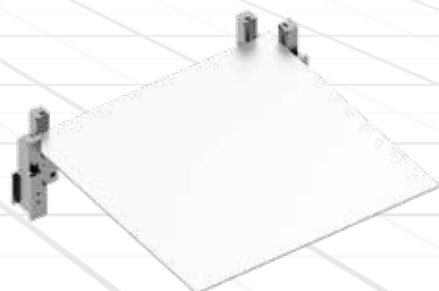
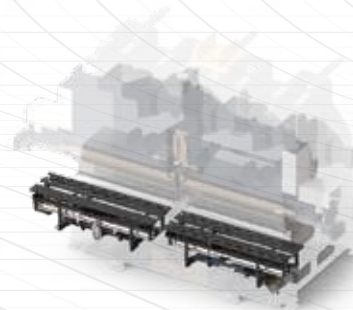

Bending Center

Working Table

The working table is placed to facilitate the flow of sheet material and to support the floors surface in linear and rotational movements. There are two types as brushed or brushed-ball. Connection is made from the sides of the manipulator carriage body. The brush level is adjusted according to the manipulator lower clamp and lower tools level.

During transportation and maintenance, the working tables can be folded without removing the connection points and access to the relevant area is provided. In addition, this folding design provides great convenience during transport.

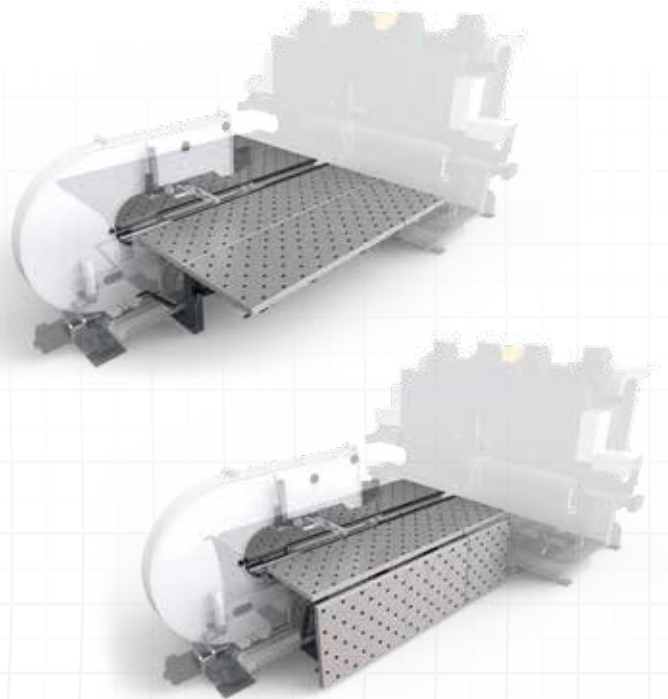

Manipulator

Manipulator is the system that provides the management of the sheet in the bending area. It performs positioning functions according to sheet positioning and bending. It catches the sheet with upper and lower clamps. After the referencing, the necessary rotation of the sheet with the starting position is determined, the positioning of the appropriate edge to the bending area, the progression between the bending steps, the steps of bringing the bent sheet to the appropriate position for evacuate are the main tasks. The manipulator is centered on the midpoint of the bending tools and positioned perpendicular to the bending axis. It performs the forward and backward movement with the servo motor driven screw shaft system placed on the carriage body, with guide carriages and linear guides placed under the manipulator body. The rotational movement of the clamps is performed by the torque motor to which the lower clamp assembly is connected. The servo motor driven system to which the upper clamp group is connected performs the positioning and tracking task according to the lower clamp.



Control Panel

The Sinumerik 840DSL CNC controller is an efficient 64-bit microprocessor system with an integrated PC. The controller has a Durma operator interface and frame bending database for all standard bending applications. The database includes the bending parameters for standard materials (steel, stainless steel, aluminium) for common thickness ranges. Based on these reference values the operator can easily improve the bending quality for different types of materials.



DURMA Cam Software

Easy to Use Bending Management

- Step by step easy programming.
- Creating program directly from DXF Drawing.
- 14 Different material type.
- For every each standart, totally 278 different metarial name.
- Sheet thinksness and folio option definitions. Editing, cleaning on DFX Drawing.
- Automatic detection for bends, part floor, bending sides.
- Definition and editing for loading parameters, shiftings can be done if necessary.
- Referencing can be easily done with visual objects.
- Parametric corrections can be done if necessary.
- Positive, negative, auxiliary, smash bend, big radius and air bend can be created with on click.
- Holder device tool management can be done.
- Recenter, cartesian, reposition can be done.
- Auxiliary tool composition can be done.
- Collision detection and machine simulation can be done.
- Bending scenerio can be followed step by step.
- Bending definition window.
- Bending simulation.
- Bending program can be exported.
- All settings, bend can be saved and reused.



Bending Center

Average Consumption

PB2
3.75
kWh



32 Servo Axes

- 1 Active - Line Module
- 18 Servo Drive Unit
- 6 PLC Control

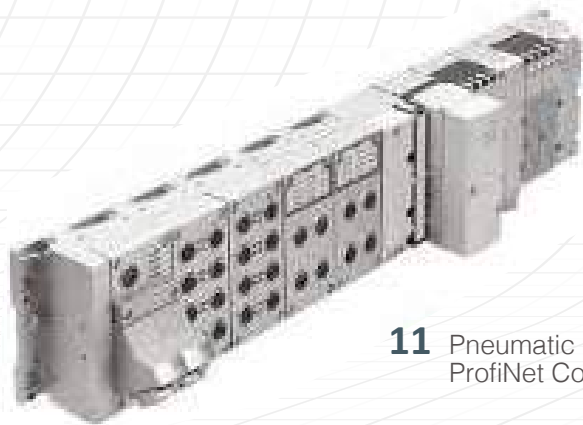

11 Pneumatic Module
ProfiNet Connection

PB4
4.5
kWh

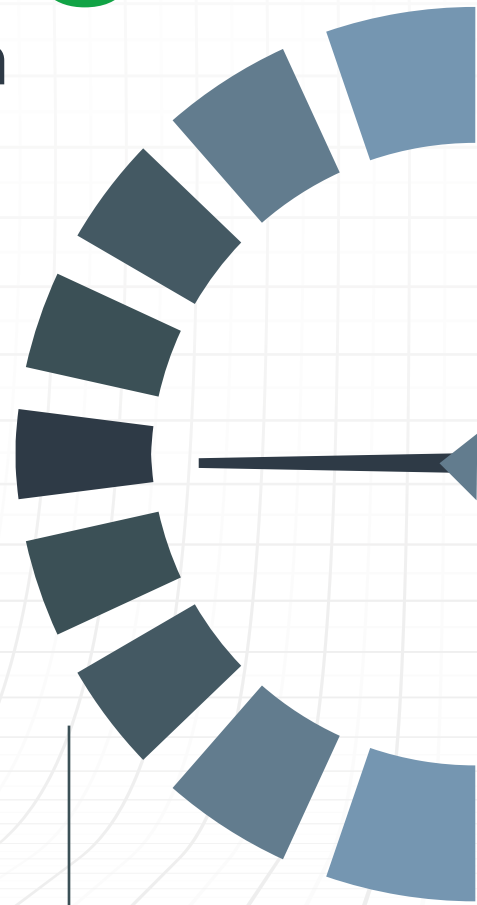

Optional Equipments

AHD (Auxiliary Holder Device)

Auxiliary holder device is a very useful option that permit to automatically change during bending cycle the geometry of the upper tool with an alternatively one when we needed, increasing the flexibility of the machine in bending capability. This option with its accessories is used to make partial bend, narrow profile deep bend, panel with embossing, hidden negative bend and more. The AHD allows to automatically changing the geometry of the upper tool with an alternatively one when needed. The option consist in a long bar (according to the machine size) moved by 2 arms. There are 2 basic positions. The "stand by" position of the bar is on the upper side of the machine. The bar working position is placed under the upper tools by a junction system. The bar is prepared to contain all different type tooling that have to be easily manually set up according to the components.

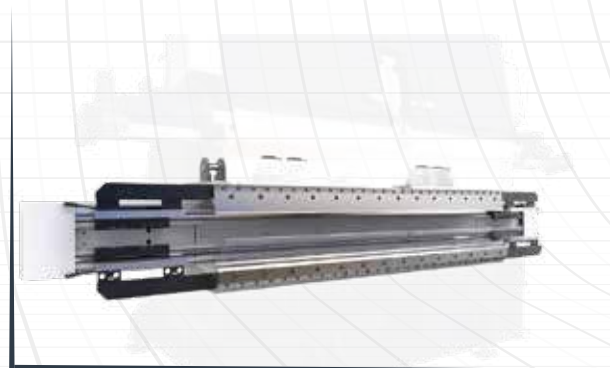

ABD (Auxiliary Bending Device)

This device is a very useful option that enlarge the bending capability of the machine. This option with its accesories is used to make bend internal the pannel contour, corner junction, partial bend, irregularly shaped panels and more. This option is located inside the C-frame and consists of four carriages sliding on linear guides parallel to the bending line and moved independently by two servomotors. The movement is made by belt driving system, precise and reliable. Every pair of carriage can moves from one side to the other covering all the machine length.

Bending Center

LUS

(Loading / Unloading System)

This device is a very useful option that enlarge the bending capability of the machine. This option with its accesories is used to make bend internal the pannel contour, corner junction, partial bend, irregularly shaped panels and more. This option is located inside the C-frame and consists of four carriages sliding on linear guides parallel to the bending line and moved independently by two servomotors. The movement is made by belt driving system, precise and reliable. Every pair of carriage can moves from one side to the other covering all the machine length.

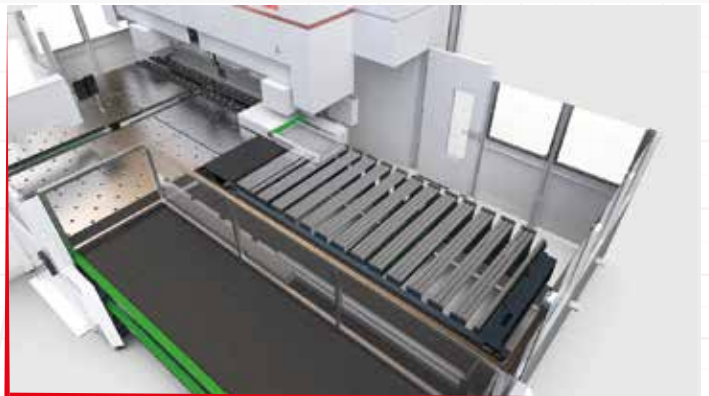
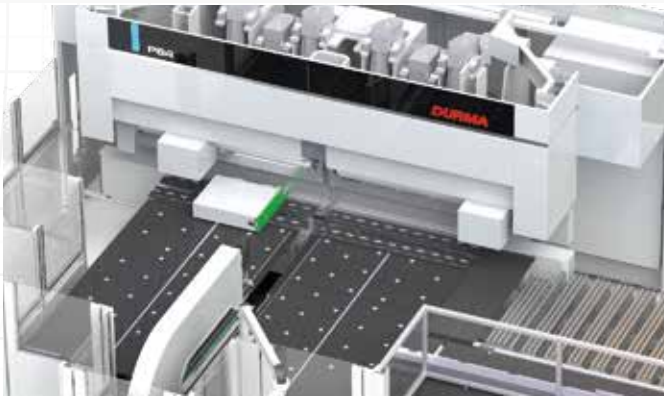

REFC

(Conveyor With Reference)

It is an option that is suitable for automation work and provides an external reference point for regular part flow into the machine bending area.

It is suitable for manual loading as well as connecting systems in line systems and robot applications.



FCON

FREE CONVEYOR

It is a system that allows the manual evacuation of the part bent in the CNC Bending Center in parallel with the production flow. With its rotary roller system placed at certain intervals, it allows the part to move easily without being damaged. With its compact structure, it easily adapts to automation systems and many machines.

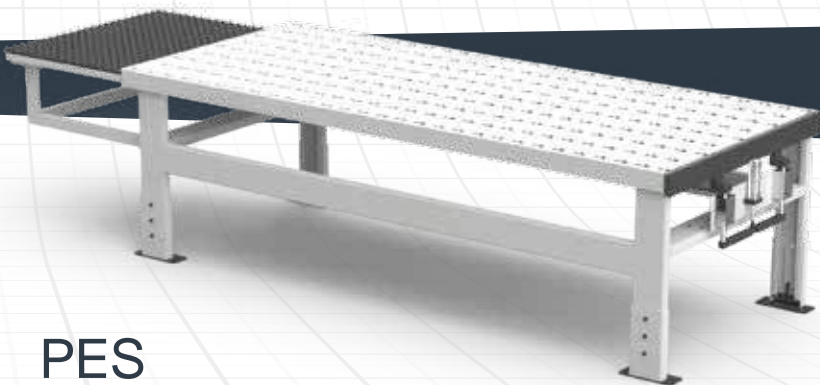

PES

(Part Evacuation System)

The PES system is another part evacuation system alternative that can be used in the production line. The belt conveyor system allows the part bent to be carried out of the machine.

It performs part evacuation at 90°, i.e., perpendicular to production flow. With the addition of the PESD (Directly) feature, it can also perform the evacuation of the parts both perpendicular and parallel to the production flow.

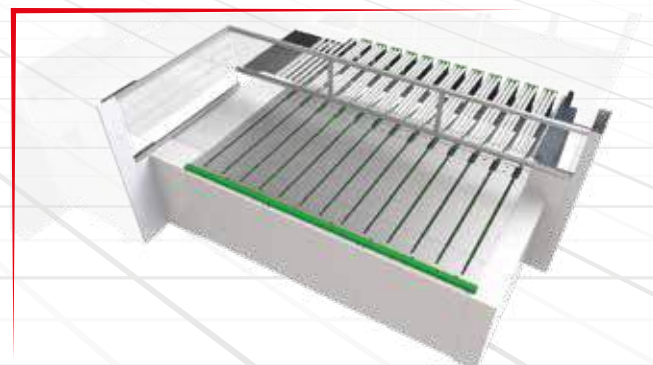

Bending Center

PPS (Pick & Place System)

PPS is an option designed for automatic loading from pallets. Loading is done by removing the blank sheet from the pallet and placing it on the reference conveyor.

The PPS 2A machine has two axes of movement, the axis that is horizontally perpendicular to the production line and the axis that moves upwards and downwards. The PPS 3A machine has three axes of movement, the horizontal axis perpendicular to the production line, the parallel axis, and the axis that move upwards and downwards. It has a pneumatic sheet separator system and double thickness measurement system.

Pick & Place 2 Axes

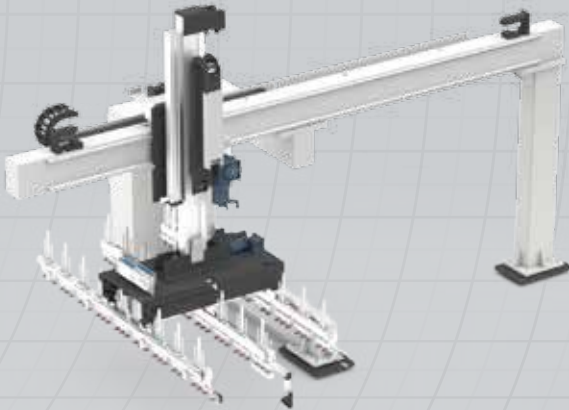

Pick & Place 3 Axes

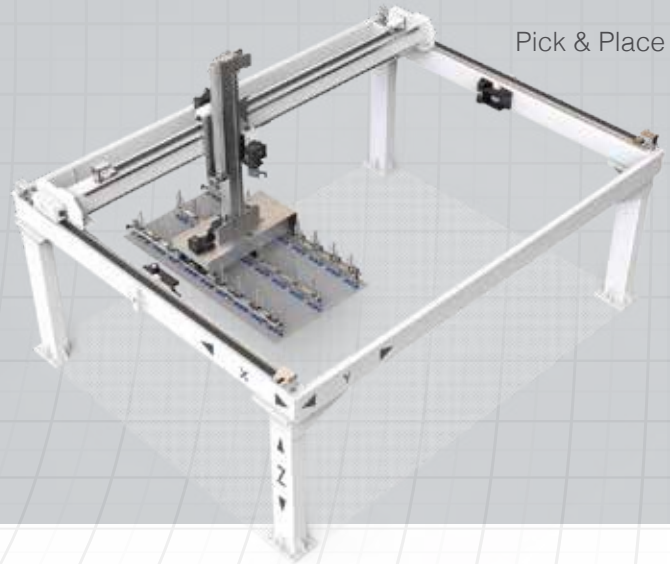

User-Friendly Interface and 2D Simulation

- New bending programs can be added to tasklist, production counts can be setted, different parts can be produced.
- Bending programs can be loaded from machine memory of USB memory stick.
- Bending programs which are placed in the machine memory, can be viewed as folder tree.
- The part which will be bended can be previewed.
- Passing through bending can be done.
- Machine axis positions can be viewed online with machine simulation.
- Tool composition can be managed and previewed online.
- Machine switch and sensor can be viewed and managed online.
- Movement, axis, setup etc. Parameters of machine can be edited, backedup, exported.

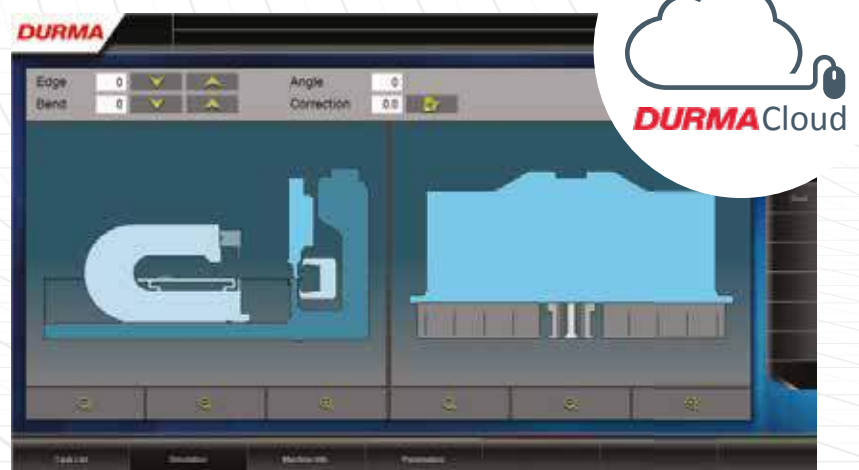

- The selected program, production status, instantaneous speed and power of the machine can be manitored online.
- The final bending parts can be taken from the reports page.
- Details of bending parts can be displayed.
- Machine alarms are archives. Posture reasons can be examined.

Bending Center

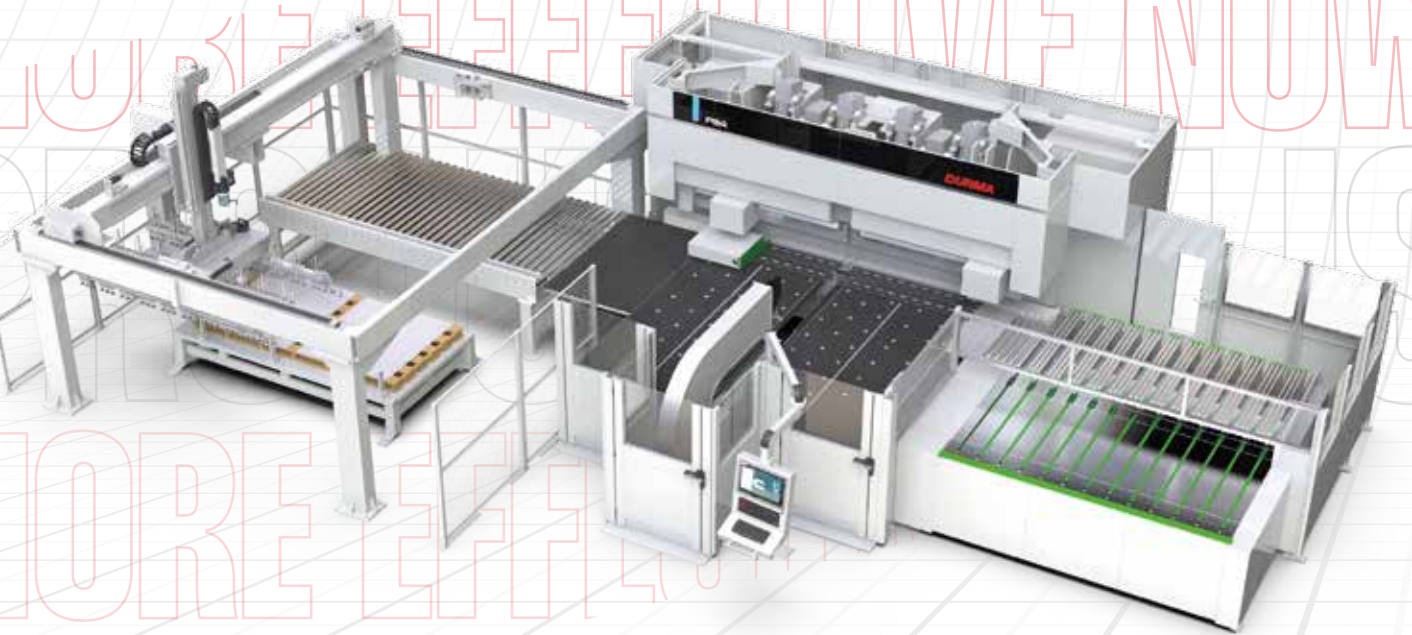
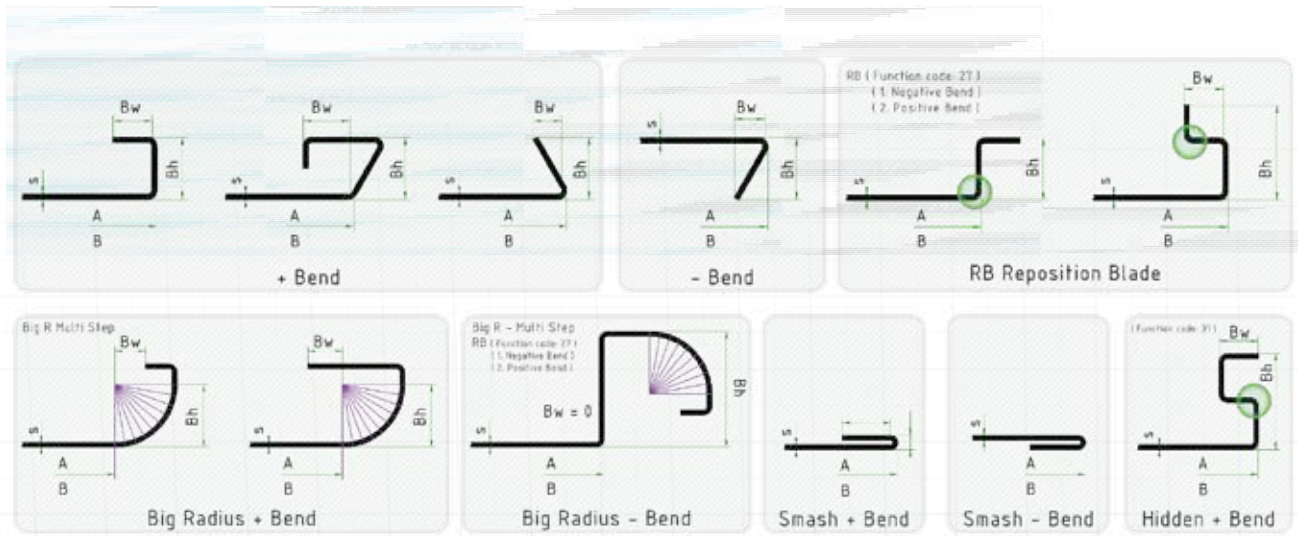

Production is *More Effective Now.*

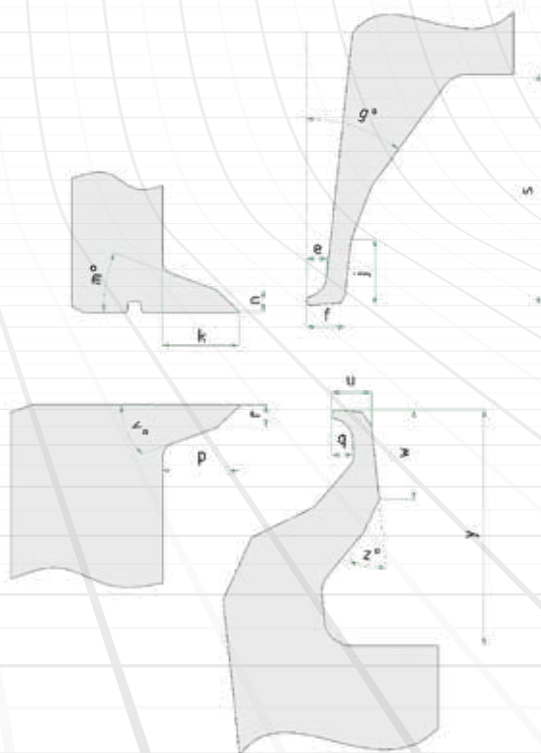
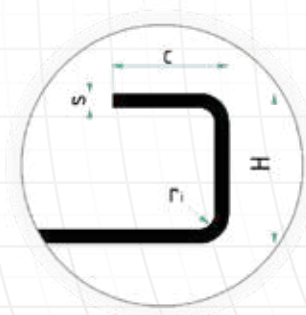
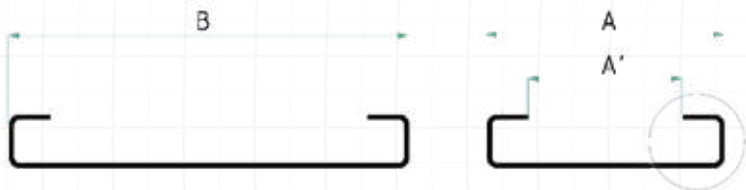
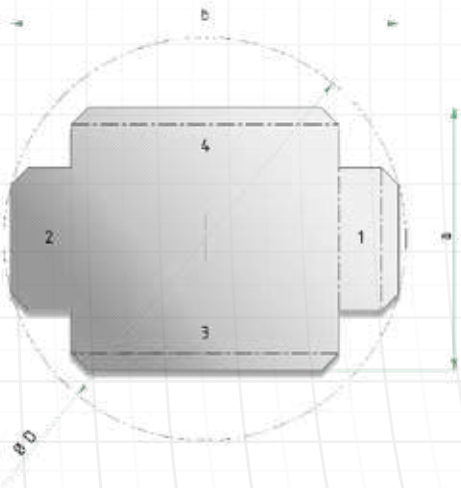
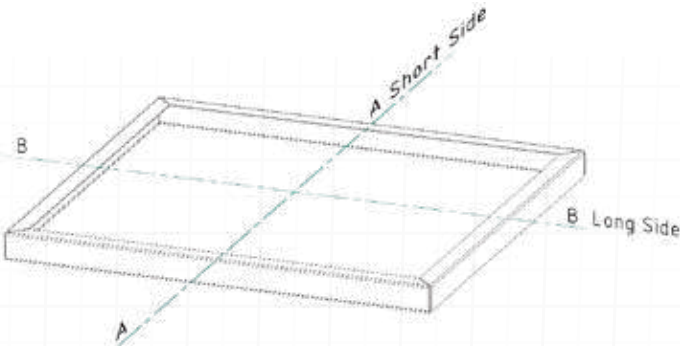

Upper Blade	e	mm	7,5
	f	mm	14
	g	°	36°
	j	mm	23,5
	s	mm	85
Lower Blade	u	mm	14
	q	mm	7,5
	w	mm	32
	z	°	32°
	y	mm	85
Upper Tool	k	mm	55
	n	mm	15
	m	°	20°
Lower Tool	r	mm	15
	p	mm	55
	v	°	20°

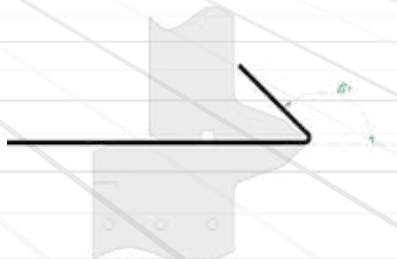

Bending Center

Standard & Optional Equipment

Standard Equipment

Universal Bending / Holding Tools
CAD-CAM software & Activator(Dongle)
Control Unit, Siemens Sinumerik 840 D SL Windows 7 Operating System
Remote Diagnostic Function
Network, Ethernet Communication
Programming on the Control Panel
ATS – Automatic Tool Setup
LUD - Loading / Unloading Device
Centering Device
Standart Clamp for Manipulator
Crowning Bending Device
Crowning Holder Device
Brush Table
USB Driver
Air Condition for Electrical Cabinet
400 V Voltage
Barriers for CE
World Standard Electric Equipment

Optional Equipment

LUS - Loading / Unloading System
AHD - Auxiliary Holder Device
ABD - Auxiliary Bending Device
PES - Part Evacuation System
REFC - Conveyor with Reference
PPS - Pick & Place System
OC - Over Clamp
NPF - Narrow Part Feeder
ENG - Engraver
Working Table (Brush & Balls)
Transformator
UPS for machine (30 kVA 10 min.)

Technical Details

Technical Specifications			PB2	PB4
Max. Bending Length		mm	2250	2800
Sheet Length	min	mm	215	
	max	mm	3048	3505
Sheet Width	min	mm	150	
	max	mm	1524	
Min. Bending Length	with re-entering bends	mm	350	
	without re-entering bends	mm	215	
Max. Sheet Diagonal		mm	2600	3300
Min. Width Between The Bends	Standard	mm	150	
	with option	mm	120 (with OC option)	
Min. Height Of The 1 st Bend			4 ÷ 5 times the thickness	
Max. Re-Entering Bend		mm	50	
Max. Bending Height		mm	254	
Distance Between The Bending Blades		mm	268	
Min. External Radius			1.5 ÷ 2 times the thickness	
Max. Bending Angle In One Step		°	±135	
Max. Acceptable Planarity Of The Blank		mm	10	
Bending Force		kN	320	500
Holding Force		kN	550	1000
Max. Thickness	Steel UTS 410 N/mm ²	mm	2,5	3,2
	Stainless Steel UTS 680 N/mm ²	mm	1,8	2,2
	Aluminium UTS 265 N/mm ²	mm	3,5	4
Min. Thickness		mm	0,5	
Average Consumption		kWh	3,75	4,5

Machine Characteristics	
Numeric Control	Siemens 840 D
Locking Tools Mechanism	Servo Electric
Crowning Bending Blade	Servo Electric
Reference Pins Control	Microswitch
Crowning Holder Device	Servo Electric
Holder Device Main Movements	4 actuators
Manipulator Clamping	Servo Electric
Negative Last Bend	Standard
Automatic Tool Setup	Standard
Axis Movements	Servo Electric
On - Off Movements	Pneumatic

**Bending
Center**

**PRODUCTION IS
MORE EFFECTIVE
NOW**

Production is *More Effective Now.*

FAST ON SERVICE AND SPARE PARTS

DURMA provides the best level of service and spare parts with qualified personnel and spare parts in stock. Our experienced and professional service personnel are always ready at your service. Our professional training and application enriched courses will give you an advantage to use our machinery.







Product Groups

DURMA



Durmazlar Makina San. Tic. A.Ş. has right to change catalogue values and machine technical details without notice.

-  Durma International
-  durmainternational
-  durmaint
-  durmamachines
-  Durmazlar



EN 2024/04/V02



Durmazlar Makina San. ve Tic. A.Ş.
OSB 75. Yıl Bulvarı Nilüfer-Bursa /
Türkiye
P: +90 224 219 18 00
F: +90 224 242 75 80
info@durmazlar.com.tr

www.durmazlar.com.tr